

## SX1PTZ-33x3M Series

### Explosion Proof PTZ Camera Station

Integrated with 3MP 33x Optical Zoom Ventionex VX1 Sony Sensor Camera Module



SX1PTZ-W



SX1PTZ-LEDW

### Main Features



Marine grade  
AISI316L Stainless  
Steel material



Ex II 2 G Ex db op pr  
IIC T6 Gb / Ex II 2 D Ex  
tb op pr IIIC T80°C Db



IP 66 / 68



Vandal-proof IK10  
ratings



Option for IEEE  
802.3bt PoE++  
(90Watt)



8MP [4K] resolution  
22x optical zoom lens



Motorized 6.4 -  
138.5mm



Option for LED  
illuminator available

## Technical Data

General	
Certification	Ex II 2 G Ex db op pr IIC T6 Gb / Ex II 2 D Ex tb op pr IIIC T80°C Db
Protection Level	IP 66 / 68, TVS 6000V Lightning Protection, Surge Protection and Voltage Transient Protection
Operating Temperature	-40°C to 60°C
Relative Humidity	≤95%
Mechanical	
Body Material	Stainless steel 316L material
Sight Glass Material	Window with hardened mineral clear tempered glass
	Window with Germanium glass (for SX1PTZ-G and SX1PTZ-GL model)
Pan & Tilt Speed	Variable speed option: 0.1°/s to 45°/s
Pan & Tilt Movement	Pan: 360° continuously      Tilt: -90° ~ +90°
Overall Dimension (WxHxD)	<i>Please refer to overall dimension drawings of each model.</i>
Weight	Approximate 38KG
Internal Usable Size for Camera Module	Ø80 x 155 mm
Wiper Mechanism	Available for all model
Cable Entries	1 x M25 (optional additional cable entry upon request)
Electrical	
Operating Voltage	AC110-240V (0.5A - 1.10A), 50/60Hz Optional: IEEE 802.3bt PoE++(90W)
Power Consumption	Max 110W (110V), Max 120W (240V)
Thermostatically Controlled Heater	T°C on: <10°C, T°C off: >10°C
Optional	
LED Illumination	Up to 200 meters (for SX1PTZ-LEDW model)
Built in Fiber Optic Module	Single Mode or Multi Mode or Dual Mode (-SM or -MM or -DM model, please refer to below ordering info)
Accessories	
Standard	Sunshield for Camera Housing
Optional	Wall Bracket, Sunshield for Pan & Tilt Body

## IP Camera/Lens

Camera	
Day/Night	Automatically removable IR-cut filter
Shutter Time	1~1/10K s
Noise Reduction	2DNR, 3DNR, NR by motion
Image Settings	Color, Brightness, Sharpness, Contrast, White Balance, Exposure Control, Masking, Text Overlay
Corridor Mode	Corridor Mode 90°, 180°, 270° rotation
Image	
Image Sensor	1/2.8" Progressive CMOS
Effective Pixels	HxV = 2065x1553 (3MP)
Pixel Size	2.5 μm
Lens	f =4.6 mm (wide) to 152.0 mm (tele), F1.6
FOV	Horizontal: 55° (wide), 2° (tele)      Vertical: 43° (wide), 1.0° (tele)
Zoom	33x Optical Zoom, up to 10x Digital Zoom
Min. Illumination	Color: 0.04Lux      B/W: 0.002Lux
Frame Rate (Maximum)	H265: HDR 3M @30fps + 720p @30fps
	H264: HDR 3M @30fps + 720p @30fps
	MJPEG: 1080p @30fps
Compression Standard	
Video Compression	H.265/H.264/MJPEG
Video Streaming	Up to 4 individually configurable streams in H.265/ H.264/ MJPEG Configurable resolution/ frame rate/ bandwidth LBR/ VBR/ CBR in H.265/ H.264
Network	
Security	User Authentication/ HTTPS/ IP Filter/ IEEE 802.1x
Supported Protocols	ARP, PPPoE, IPv4/v6, ICMP, IGMP, QoS, TCP, UDP, DHCP, UPnP, SNMP, SMTP, RTP, RTSP, HTTP, HTTPS, FTP, NTP, DDNS
ONVIF	Profile S/ G/ Q/ T conformant
System Integration	
General Events	Motion Detection/ Tampering
Intelligent Video Analytics	<i>(optional upon request)</i> Human, Vehicle & Object Detections for Tripwire / Intrusion / Loitering / Abandoned Object / Missing Object / Parking Detection / Crowd Detection
Advanced Analytics	<i>(optional upon request)</i> Fire Detection or Smoke Detection
Intelligent Platform	<i>(optional upon request)</i> Simplify Unified Intelligent Platform Integration, Radar Tracking Integration
General	
Storage	Support for microSD/ microSDHC/ microSDXC card (up to 512GB) Support for recording to NAS

\*Analog camera and other camera module options are available upon request.

\*Thermal camera options are available for G model. Please contact us for the details

## Outline Dimensions (mm)

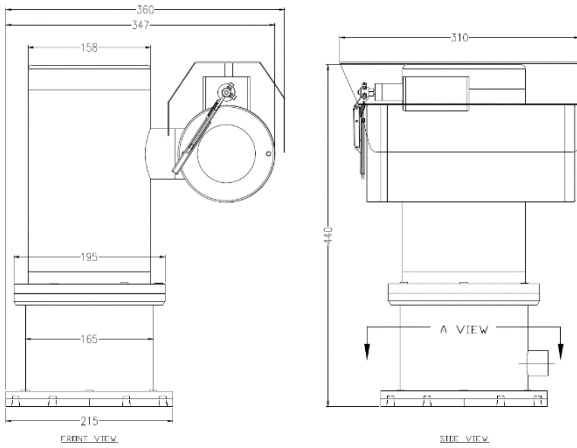

SX1PTZ-W Outline Dimensions

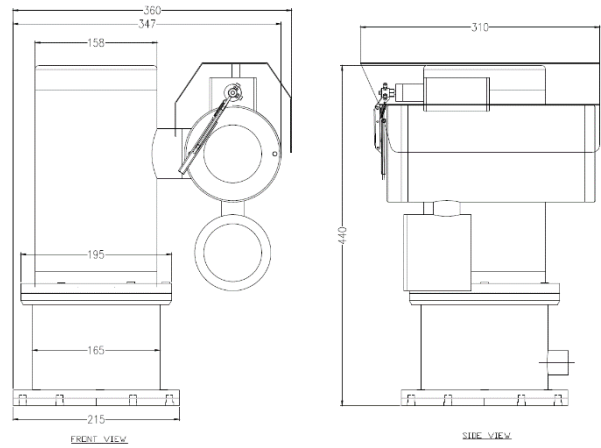

SX1PTZ-LEDW Outline Dimensions

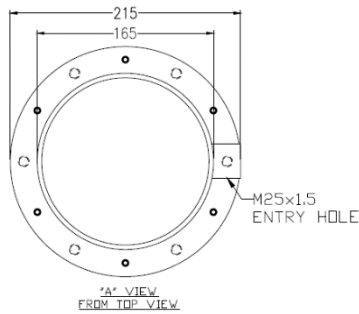

Base View from Top

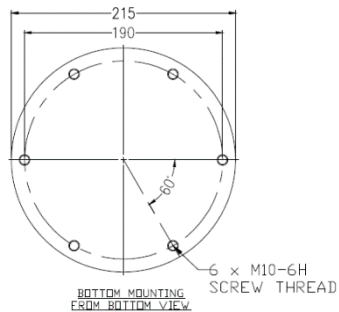

Base View from Bottom for Mounting

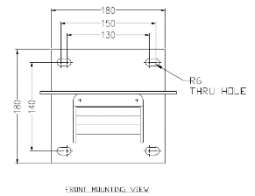
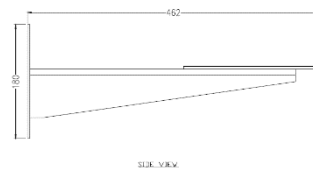
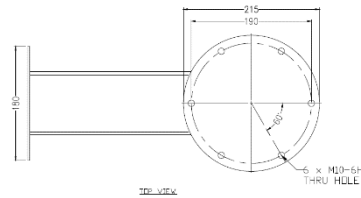

WB-SX1PTZ - Wall Bracket Outline Dimensions

## Model & Ordering Code

---

SX1PTZ - X - 33x3M - X - X

POE Options

Blank : No additional option  
POE : POE++

Built-in Fiber Optic Module Options

SM : Single Mode  
MM : Multi Mode  
DM : Dual Mode

Camera Station Options

W : Fitted with wiper mechanism  
LEDW : With LED Illuminator and Wiper

## Standard Accessories

SCH-SX1PTZ : Sunshield for Camera Housing

## Optional Accessories

WB-SX1PTZ : Wall Bracket  
SPT-SX1PTZ : Sunshield for Pan & Tilt Body